



AUTOMATIC BROILERS

ITEM NO. AIA 11400

MODEL 1015A G

The Model 1015A is ideal for flame broiling steaks, gourmet hamburgers, chops, fish and a variety of other menu basics. The versatility of the 1015A make it a workhorse in the kitchen.

FEATURES

Flow-through Operation
Side Burner Access Panel

OPTIONS

Stripper Blades
Entree Shelves
One to Three Broil Belts
Natural or Propane Gas

ACCESSORIES

Spare Motor
Spare Parts Kit
Quick Disconnect Gas Hose
(where permitted)
Stainless Steel Stand with Casters

THE NIECO ADVANTAGE

All Nieco equipment is backed by a world-wide sales and service network, with local parts inventories and 24-hour emergency service. Included in the price of the Nieco Broiler is a visit by an authorized distributor representative to start-up the broiler, activate the warranty and train the store personnel on cleaning and operating the broiler.



BENEFITS OF AUTOMATION:

- Consistency*
- Versatility*
- Speed*
- Quality*
- Flexibility*

APPROVALS:



DISTRIBUTED BY:

NIECO CORPORATION

7950 Cameron Drive
Windsor, CA 95492
707.284.7100
Fax 707.284.7430
www.nieco.com email: sales@nieco.com
Re-order P/N 9999-99097 10/01



AUTOMATIC BROILERS

AUTOMATIC BROILER

Model 1015A G

DIMENSIONS	INCH	MM
Length	54 3/16	1376
Height	31 9/32	795
Width	33 11/16	856

ENERGY - GAS MODELS

Gas connection 3/4" N.P.T.

Electrical connection (specify exact voltage)

Domestic	120V IØ 50/69Hz 5A
Export	200-240V IØ 50/60Hz 5A

Avg. KW/hr .6

Natural Gas	4" W.C.
BTU/hr	120,000
KCAL/hr	30,240

Liquid Propane	11" W.C.
BTU/hr	120,000
KCAL/hr	30,240

**ENERGY ELECTRIC MODELS
NOT AVAILABLE IN ELECTRIC**

WEIGHT	LB	KG
Shipping	485	220

EXHAUST	CFM	CMH
Typical	1000	1699

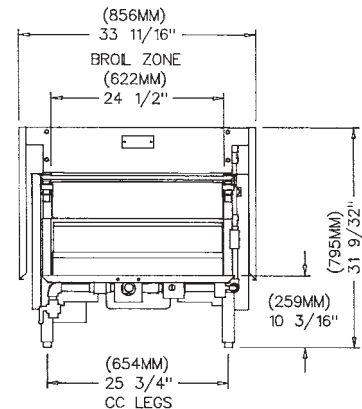
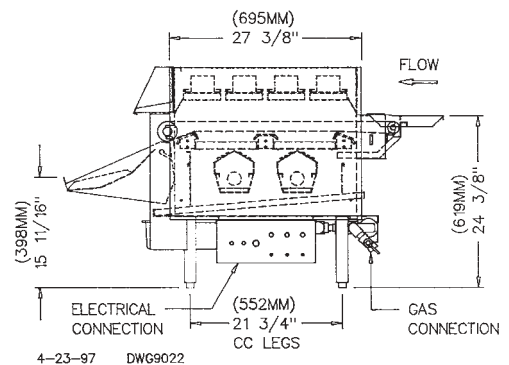
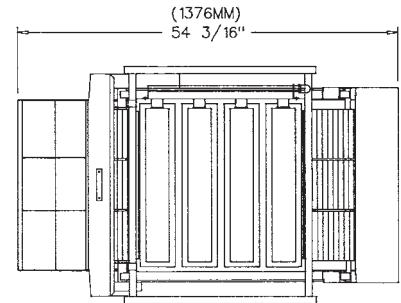

BIDDING INFORMATION

Nieco Model 1015A, using infrared heating and a continuous chain conveyor. Broiler shall be constructed of stainless steel frame with stainless steel enclosure panels.

Model 1015A, shall be gas-fired, infrared and manufactured to operate on Natural Gas at 4" W.C., or Liquid Propane at 11" W.C., at the factory. Broiler shall have 6 burners - 4 top and 2 bottom, and side access for lower burner removal.

Model 1015A shall be equipped with up to three, eight-inch (standard), independently controlled meat belts. Broil belts shall be individually timed by an analog speed controller, and shall be constructed of stainless steel and supported by non-lubricated bearings.

NIECO CORPORATION

7950 Cameron Drive
Windsor, CA 95492
707.284.7100
Fax 707.284.7430
www.nieco.com email: sales@nieco.com
Re-order P/N 9999-99097 Printed in the USA
© 2001 Nieco Corporation