



ITEM NO. AIA 11400

## AUTOMATIC BROILERS

### MODEL N524 / N550 G

The Nieco Models N524 & N550 have been designed for medium volume restaurants, kiosks or other applications where product return is needed. The Model N550 features dual broil belts, while the N524 has one broil belt.

### FEATURES

- Digital Controls
- Automatic Ignition
- Side Burner Access Panel
- Heated Meat Holding Section (Return-flow)
- Automatic Temperature Control
- Flow-through or Return-flow Operation

### OPTIONS

- Stand
- Catalyst Kit
- Spare Motor
- Spare Parts Kit
- Automatic Feeder
- Natural or Propane Gas
- Single or Dual Broil Belts

### ACCESSORIES

- Quick Disconnect Gas Hose  
(where permitted)

### THE NIECO ADVANTAGE

All Nieco equipment is backed by a world-wide sales and service network, with local parts inventories and 24-hour emergency service. Included in the price of the Nieco Broiler is a visit by an authorized distributor representative to start-up the broiler, activate the warranty and demonstrate to the store personnel how to clean and operate the broiler.

### NIECO CORPORATION

7950 Cameron Drive  
Windsor, CA 95492  
707.284.7100  
Fax 707.284.7430  
www.nieco.com email: sales@nieco.com  
Re-order P/N 9999-99162 4.04



Model N550 shown with optional automatic feeder and stand

### BENEFITS OF AUTOMATION:

- Consistency
- Versatility
- Speed
- Quality
- Flexibility

### APPROVALS:



### DISTRIBUTED BY:



**AUTOMATIC BROILERS**

**AUTOMATIC BROILER**  
*Model N524 & N550 G*

DIMENSIONS	INCH	MM
Length	36.58	929
Height	35.00	889
Width	37.38	950

**ENERGY - GAS MODELS**

Gas connection 3/4" N.P.T.

Electrical connection (specify exact voltage)

Domestic 115V IØ 50/60Hz 7A

Natural Gas	3" W.C.	5" W.C.
BTU/hr	71,200	86,600

WEIGHT	LB	KG
Shipping	440	200

EXHAUST	CFM	CMH
Typical	600	1020

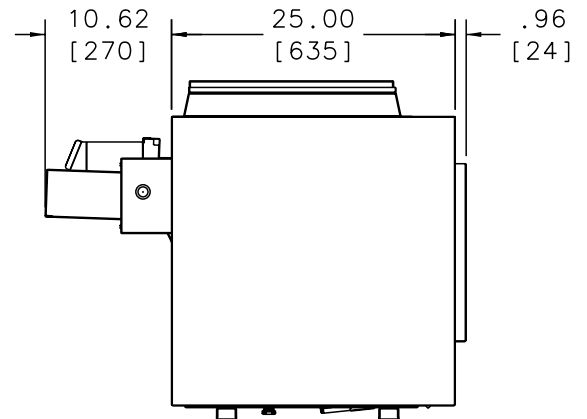
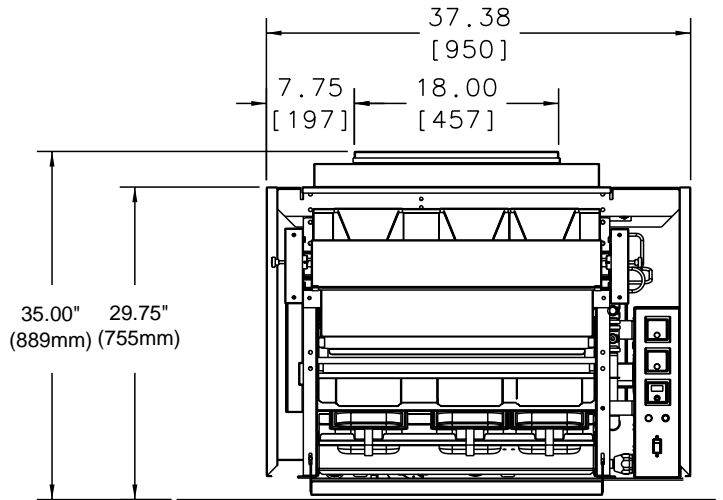

**BIDDING INFORMATION**

Nieco Model N524 & N550, using infrared and convective heating and a continuous chain conveyor. Broiler shall be constructed of stainless steel frame with stainless steel enclosure panels.

Model N524 & N550, shall be gas-fired or electric, and manufactured to operate on Natural Gas at 3" & 5" W.C., at the factory. Broiler shall have 5 burners - 3 top and 2 bottom, and side access for lower burner removal.

Model N550 shall be equipped with up to two independently controlled meat belts. Broil belts shall be individually timed by a digital speed controller, and shall be constructed of stainless steel and supported by non-lubricated bearings.

**NIECO CORPORATION**

7950 Cameron Drive  
 Windsor, CA 95492  
 707.284.7100  
 Fax 707.284.7430  
 www.nieco.com email: sales@nieco.com  
 Printed in the USA  
 © 2003 Nieco Corporation  
 P/N 9999-99162 4.04