



ITEM NO. AIA 11400

AUTOMATIC BROILERS

MODEL N512 G & E

The Nieco Model N1512 has been designed for medium volume restaurants, kiosks or other applications where product return is needed.

FEATURES

- Digital Controls
- Single Broil Belt
- Automatic Ignition
- Return-flow Operation
- Side Burner Access Panel
- Heated Meat Holding Section
- Automatic Temperature Control

OPTIONS

- Stand
- Spare Motor
- Catalyst Kit
- Spare Parts Kit
- Automatic Feeder
- Product Holding Pans
- Natural or Propane Gas

ACCESSORIES

Quick Disconnect Gas Hose
(where permitted)

THE NIECO ADVANTAGE

All Nieco equipment is backed by a world-wide sales and service network, with local parts inventories and 24-hour emergency service. Included in the price of the Nieco Broiler is a visit by an authorized distributor representative to start-up the broiler, activate the warranty and demonstrate to the store personnel how to clean and operate the broiler.

NIECO CORPORATION

7950 Cameron Drive
Windsor, CA 95492
707.284.7100
Fax 707.284.7430
www.nieco.com email: sales@nieco.com
Re-order P/N 9999-99168 8.03



Model N512 shown with optional feeder and product holding pans

BENEFITS OF AUTOMATION:

- Consistency
- Versatility
- Speed
- Quality
- Flexibility

APPROVALS:



DISTRIBUTED BY:



AUTOMATIC BROILERS

AUTOMATIC BROILER

Model N512 G & E

DIMENSIONS	INCH	MM
Length	29.00	737
Height	34.34	872
Width	27.92	709

ENERGY - GAS MODELS

Gas connection 3/4" N.P.T.

Electrical connection (specify exact voltage)

Domestic 115V IØ 50/60Hz 6.4A

Natural Gas	3" W.C.	5" W.C.
BTU/hr	60,500	77,500
kW/hr	17.7	22.7

ENERGY - ELECTRIC MODELS

208V 50/60Hz 3Ø 35A 10.2 kW/hr

WEIGHT	LB	KG
Shipping	250	125

EXHAUST	CFM	CMH
Typical	600	1020

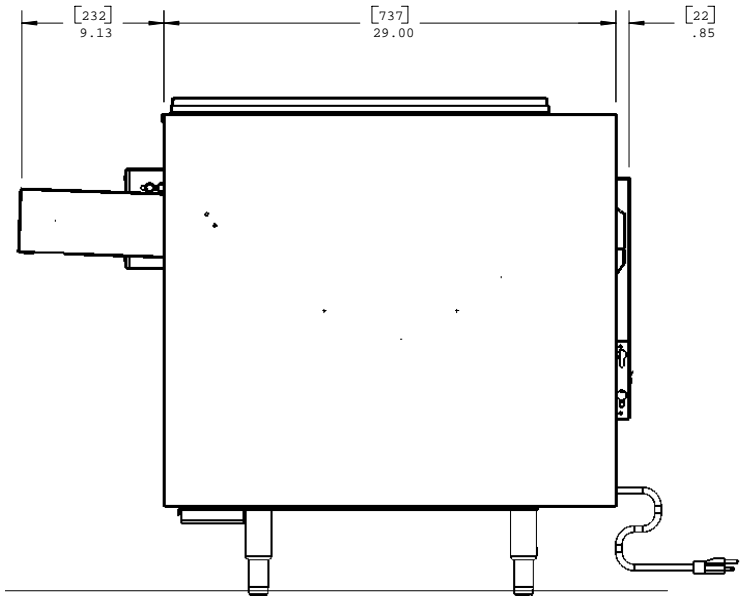
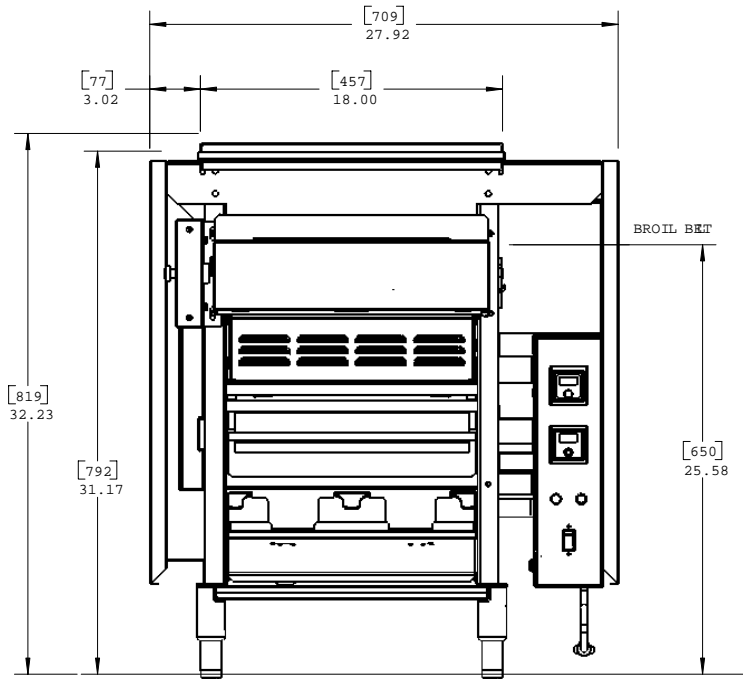

NIECO CORPORATION

7950 Cameron Drive

Windsor, CA 95492

707.284.7100

Fax 707.284.7430

www.nieco.com email: sales@nieco.com

Printed in the USA

© 2003 Nieco Corporation

P/N 9999-99168 8.03